

±124,779 SF Available for Lease

INDUSTRIAL BUILDING

10955 Arrow Route, Rancho Cucamonga, CA 91730



PROPERTY FEATURES:

- ±124,779 SF Situated on ±6.3 Acre Site
- ±8,740 SF of Office
- Bonus Mezzanine / Showroom
- 20' - 24' Clear Height
- 2,000 Amps, 277/480 Volt, 3 Phase/4-Wire
- 8 Dock High Doors
- 4 Ground Level Doors
- 2 Exterior Docks with Ground Level Access
- .23-.29/2000 Sprinkler System
- T-8 Lighting with Motion Sensors
- Large Paved Yard
- 120' Truck Court with 60' Concrete Truck Apron
- Zoning: GI - General Industrial
- Built in 1972
- Easy Access to the I-10, I-15 & CA-210 Fwys
- Close Proximity to Ontario International Airport

MICHAEL GIULIANO
mgiuliano@lee-assoc.com
C 951.314.2195
License No. 01211757

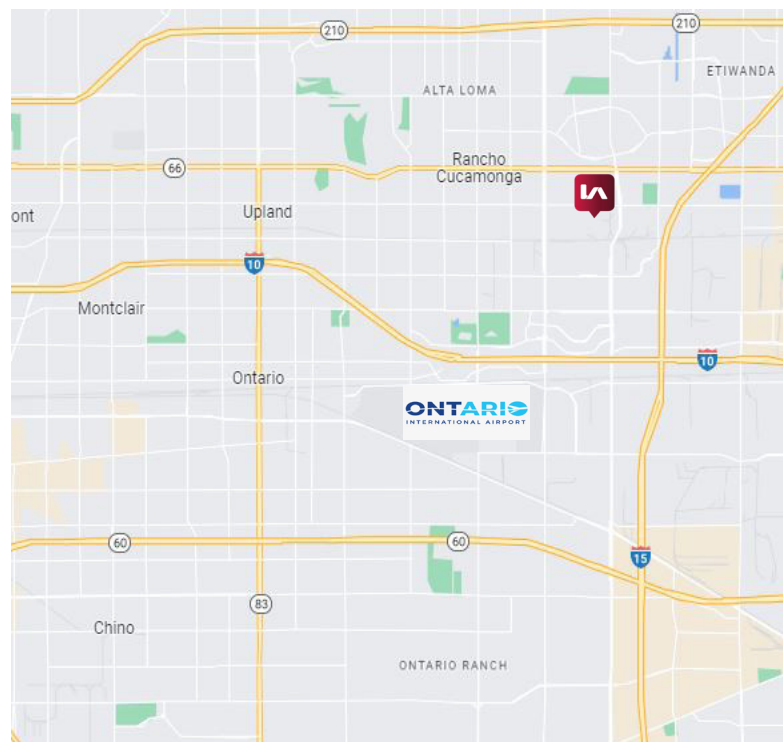

All information furnished regarding property for sale, rental or financing is from sources deemed reliable, but no warranty or representation is made to the accuracy thereof and same is submitted to errors, omissions, change of price, rental or other conditions prior to sale, lease or financing or withdrawal without notice. No liability of any kind is to be imposed on the broker herein.

±124,779 SF Available for Lease

INDUSTRIAL BUILDING

10955 Arrow Route, Rancho Cucamonga, CA 91730

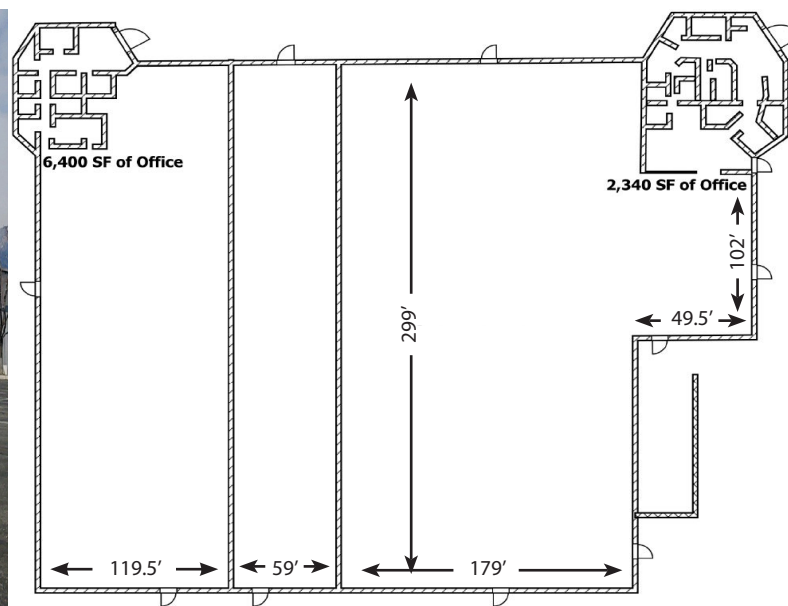
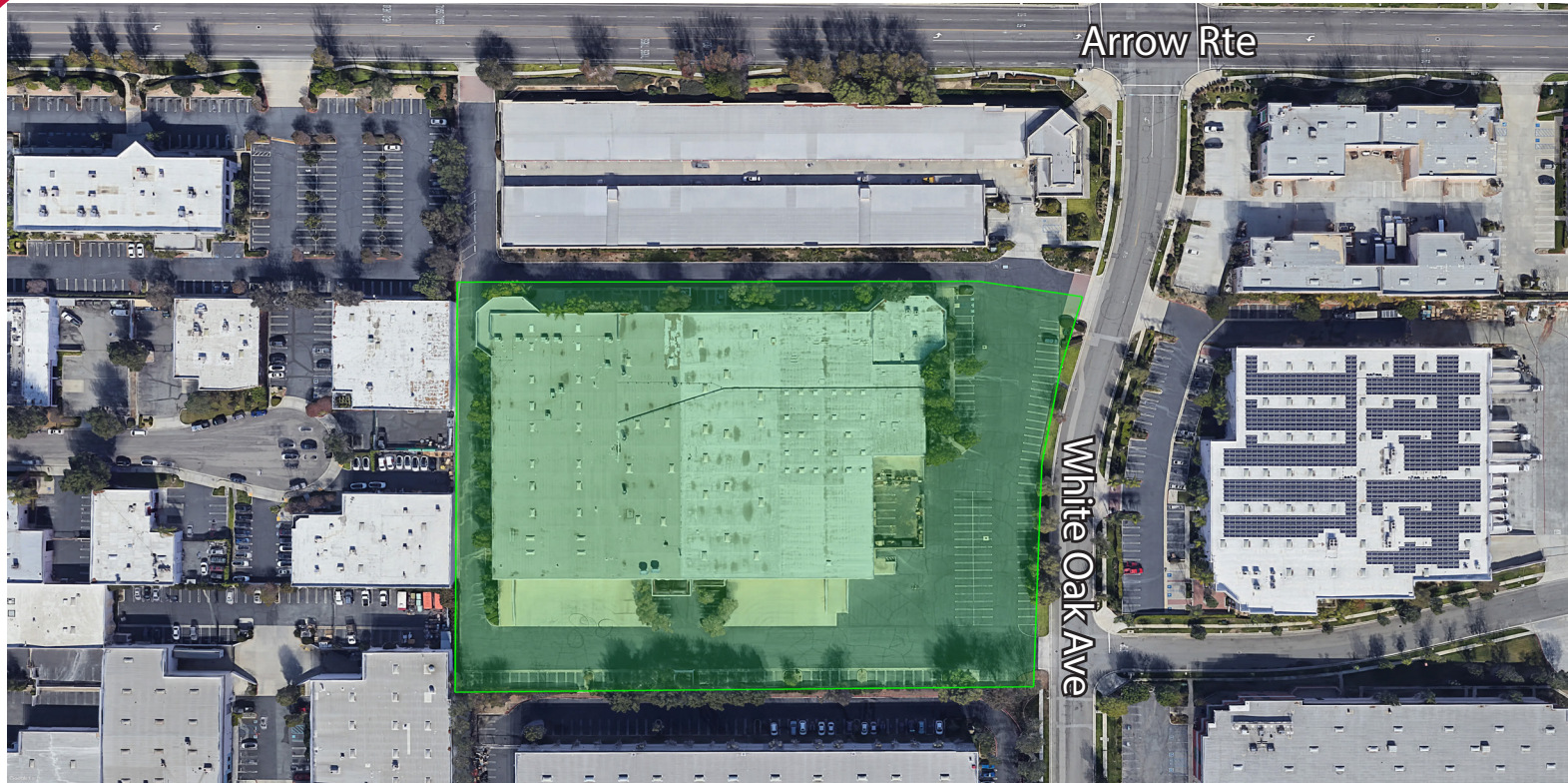

For more information,
Please contact:

MICHAEL GIULIANO
mgiuliano@lee-assoc.com
C 951.314.2195
License No. 01211757

All information furnished regarding property for sale, rental or financing is from sources deemed reliable, but no warranty or representation is made to the accuracy thereof and same is submitted to errors, omissions, change of price, rental or other conditions prior to sale, lease or financing or withdrawal without notice. No liability of any kind is to be imposed on the broker herein.